



AMERICAN EAGLE[®]
FOOD MACHINERY, INC.

AE-1220
40 Quart Fixed Bowl
Spiral Mixer

773.376.0800 (P) • 773.376.2010 (F) • 3131 S. Canal St. Chicago, IL 60616

Spiral Mixing Technology: The Secret To The Best Dough!

American Eagle® Spiral Mixers Imitate Hand Kneading And Rolling Motions. The Gentle Coordinated Movement Of Bowl And Agitator Keeps Dough Cool While Mixing For Consistent Texture. Dough Doesn't Over-Develop And Blends In Half The Time As A Comparable Planetary Mixer!

Quality Design

- Dual Motor System, 1.5 HP Agitator, 0.5 HP Bowl
- Heavy Duty Unimold Cast Iron Construction
- Fixed 40 Quart Stainless Steel Bowl (26lbs Flour / 44lbs Dough)
- Durable Multiple V-belt Drive Transmission
- Motor Start-Up Relay System Reduces Stress On Belts
- Superior Electronic Components Ensure Reliable Operation
- Enamel Coating Resists Scratches, Dents, And Rust
- ETL Certified To Conform To NSF/ANSI 8, CSA, CE Standards



**Easy To Clean
Stainless Steel
Safety Guard
and Bowl**



Standard Features

- Convenient 3 Mode Switch For Reversible Bowl (Clockwise/ Stop/Counter-Clockwise)
- 2 Fixed Agitator Speeds With Convenient Control Switch
- Thermal Overload Protection
- Safety Guard With Auto-Shutoff
- Guard Opening For Adding Ingredients While Mixing
- Heavy Duty, 7 Foot, Four Wire Power Cable*
- OPTIONAL: Digital Control Panel
- 1 Year Limited Warranty*

*Warranty must be registered. Improper wiring to plug and electrical service will void warranty, improper installation voids warranty, refer to operation manual for details. Extended Warranty available at extra cost.

Proud Member of:
NAFEM
North American Association of
Food Equipment Manufacturers

Quality • Value • Reliability



AMERICAN EAGLE[®]
FOOD MACHINERY, INC.

AE-1220
40 Quart Fixed Bowl
Spiral Mixer

sales@ameagle.biz • www.americaneaglemachine.com

Lower Your Total Cost Of Ownership With American Eagle® Spiral Mixers! Quality Design, Competitive Pricing, And Reliable Support Make Us The Value Leader In The Industry.

Specifications

Model	Capacity***	Motor	Voltage V/HZ/PH	Amps	Transmission	Agitator Speeds (RPMs)	Safety Guard	Timer
AE-1220	40 Quarts Max 26 lbs. of flour Max 44 lbs of dough	1.5 HP Agitator 0.5 HP Bowl	220 / 60 / 3	7 / 4	Belt Driven	1st: 142 2nd: 284	Yes	No

Other Available Sizes:

- AE-3050 80 Quart, 110 lbs Dough, 66lbs Flour
- AE-4065 100 Quart, 154 lbs Dough, 99 lbs Flour
- AE-5080 120 Quart, 176 lbs Dough, 110 lbs Flour
- AE-75K 190 Quart, 264 lbs Dough, 145 lbs Flour
- AE-100K** 220 Quart, 330 lbs Dough, 220 lbs Flour
- AE-125K** 250 Quart, 396 lbs Dough, 275 lbs Flour

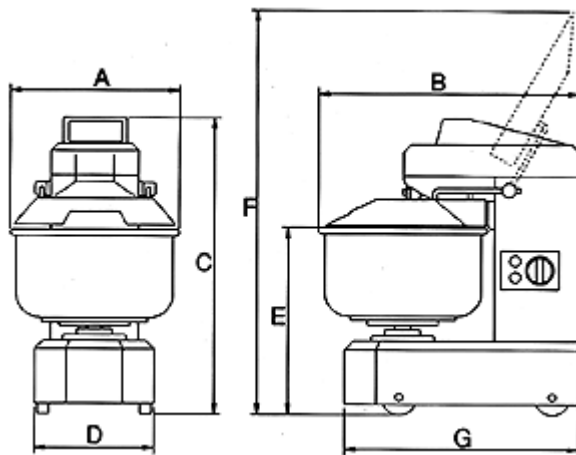

Measurements

Dimension	Inches	Centimeters
A	20	50.8
B	33	83.9
C	38	96.5
D	15	38.1
E	25.5	64.77
F	48.5	123.2
G	29.8	75.7

Dimensions and Shipping Information

Model	Overall Dimensions (w/Guard Raised)	Foot Print	Net Weight	Shipping Dimensions****	Ship Weight	Freight Class
AE-1220	20"W x 33"L x 38" (48.5") H	15"W x 32.8"D	331 lbs. (150 kg)	25.2"W x 40.2"L x 48.5"H	450 lbs. (204 kg)	85

** Special Order Item

***Capacity will be diminished depending on dough density, rated capacities are for typical bread dough. Overloading will void warranty

****Crates are affixed to a skid (pallet). The weight and dimensions of this skid are included above and may between shipments.



Quality • Value • Reliability